

A

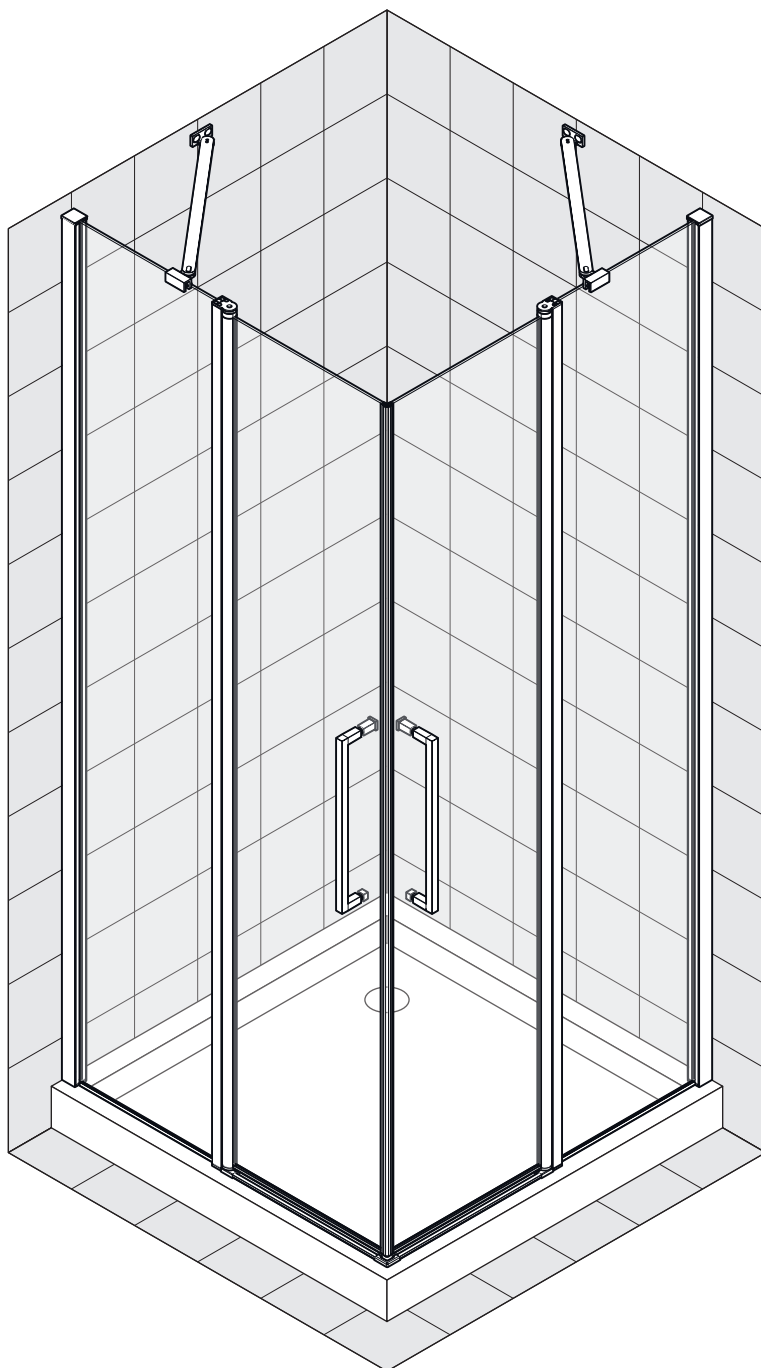

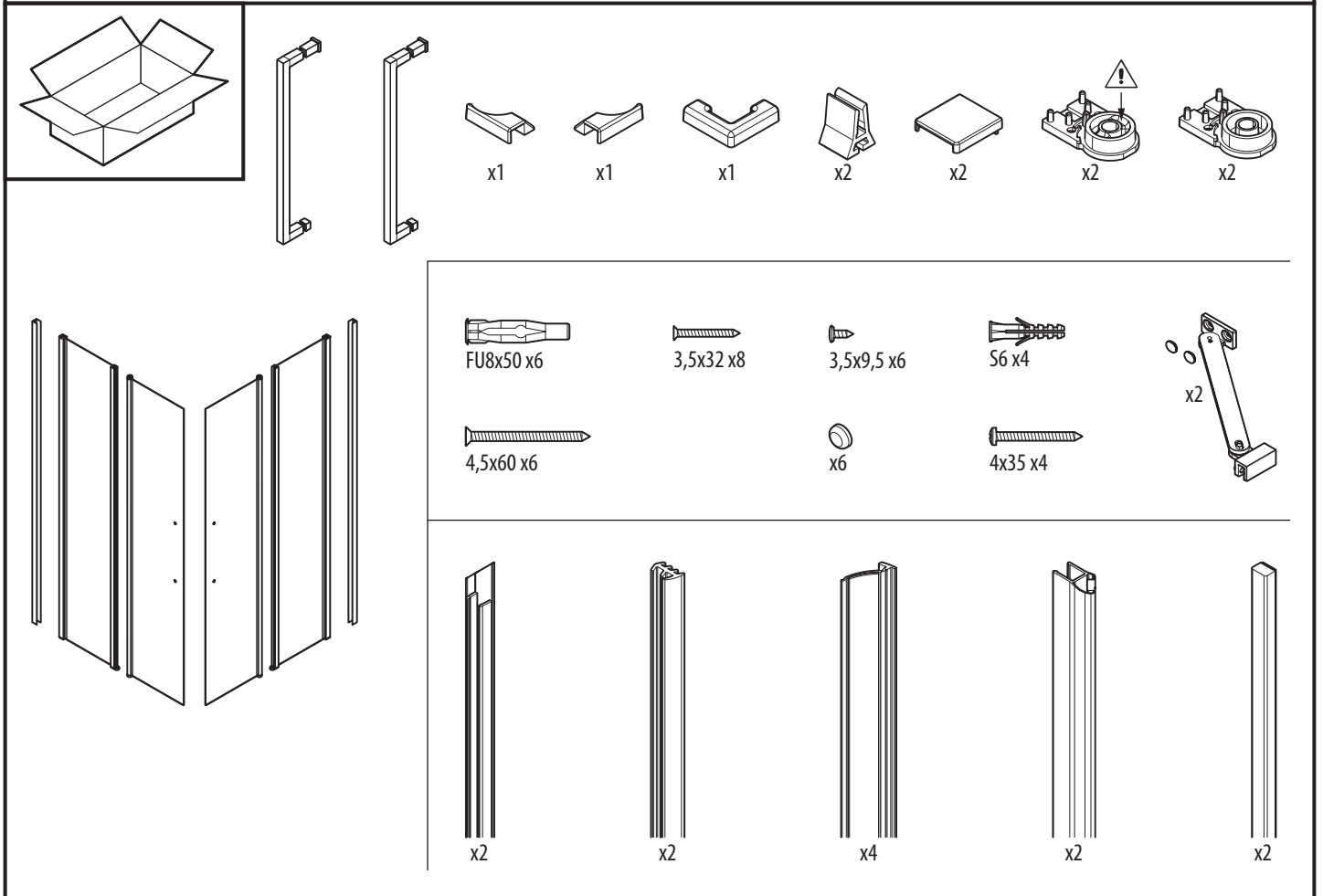
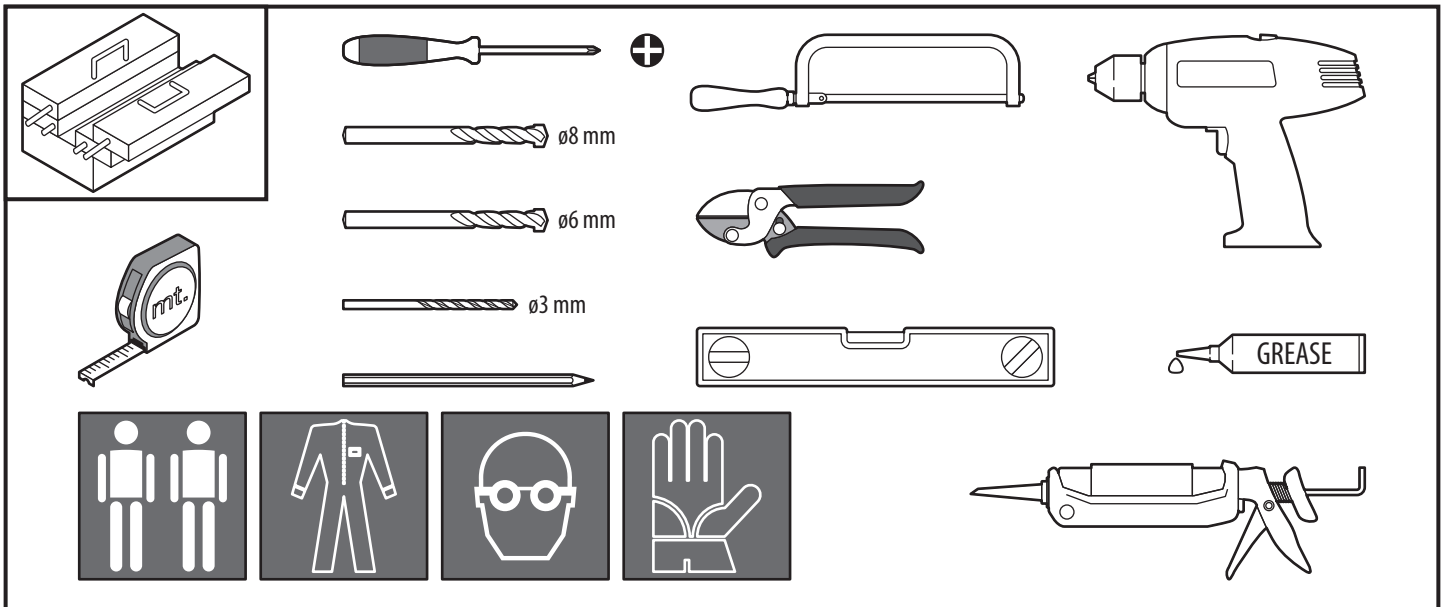

A	P	L1-L2 mm
57	580-600	570-590
59	600-620	590-610
61	620-640	610-630
65	660-680	650-670
67	680-700	670-690
69	700-720	690-710
73	740-760	730-750
75	760-780	750-770
76	770-790	760-780
77	780-800	770-790
79	800-820	790-810
81	820-840	810-830
85	860-880	850-870
87	880-900	870-890
89	900-920	890-910
91	920-940	910-930
95	960-980	950-970
97	980-1000	970-990
99	1000-1020	990-1010
101	1020-1040	1010-1030

A	V	L1-L2 mm
57	557-577	570-590
59	577-597	590-610
61	597-617	610-630
65	637-657	650-670
67	657-677	670-690
69	677-697	690-710
73	717-737	730-750
75	737-757	750-770
76	747-767	760-780
77	757-777	770-790
79	777-797	790-810
81	797-817	810-830
85	837-857	850-870
87	857-877	870-890
89	877-897	890-910
91	897-917	910-930
95	937-957	950-970
97	957-977	970-990
99	977-997	990-1010
101	997-1017	1010-1030

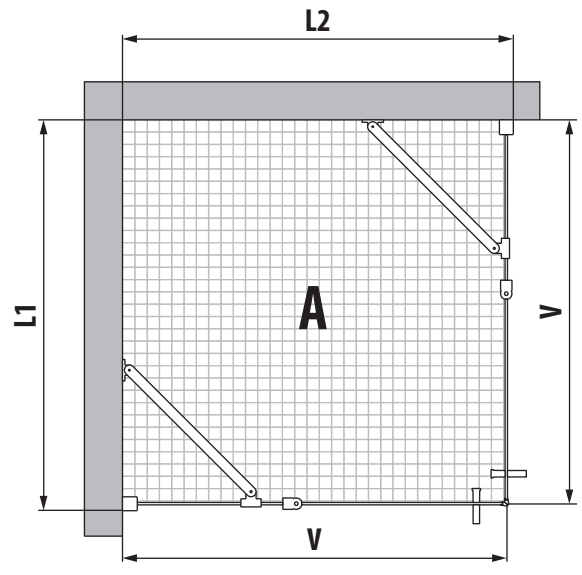
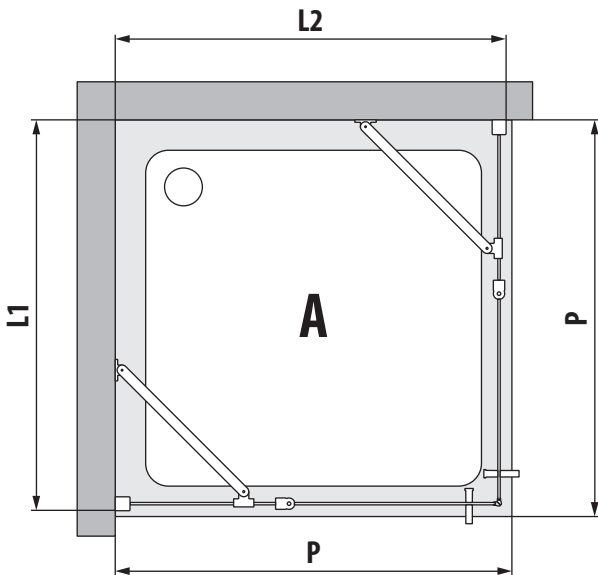

1

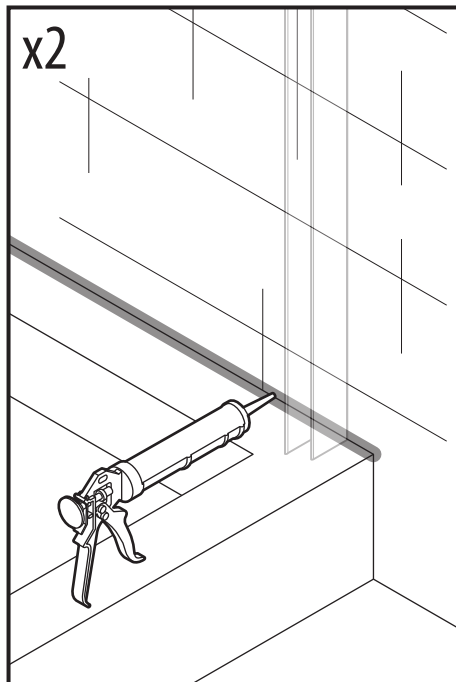
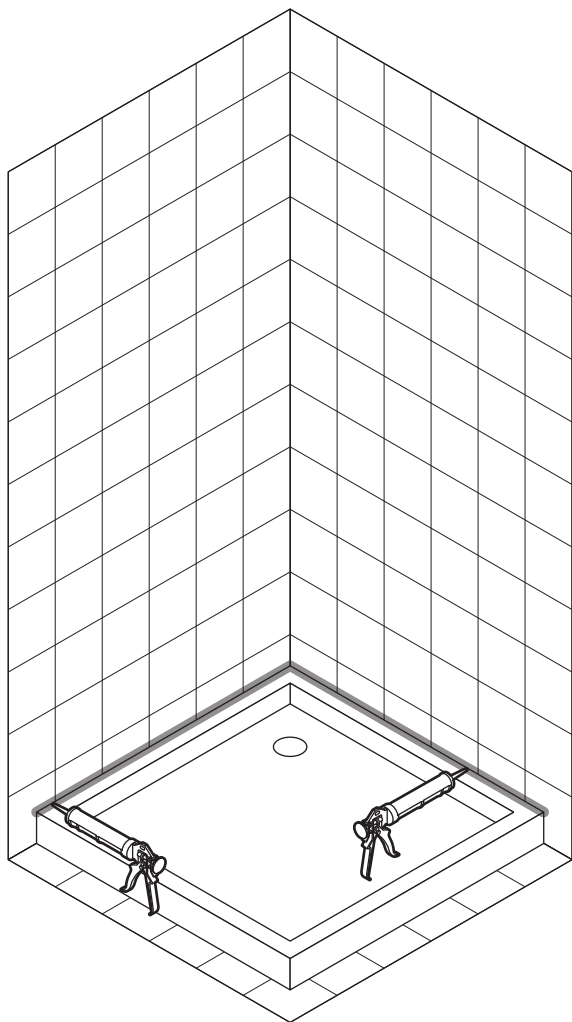

2

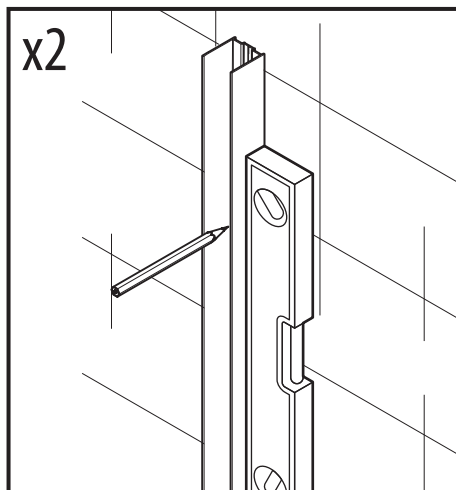
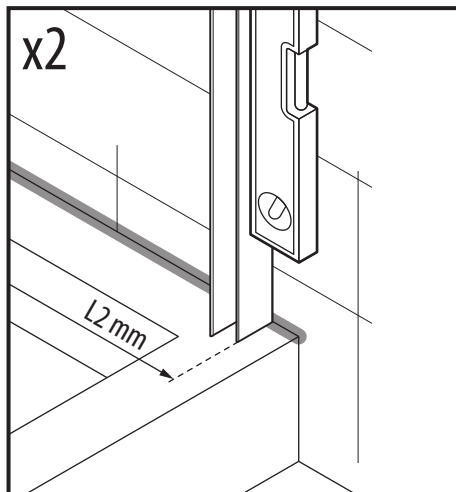
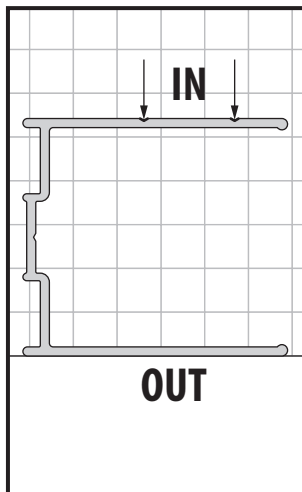
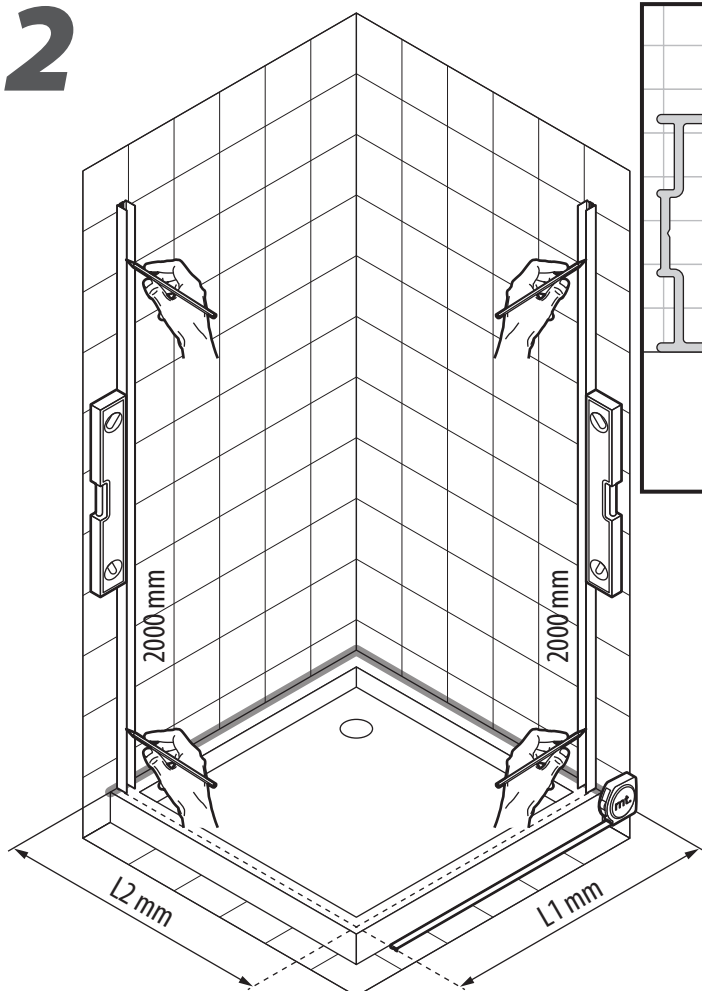

3

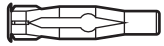
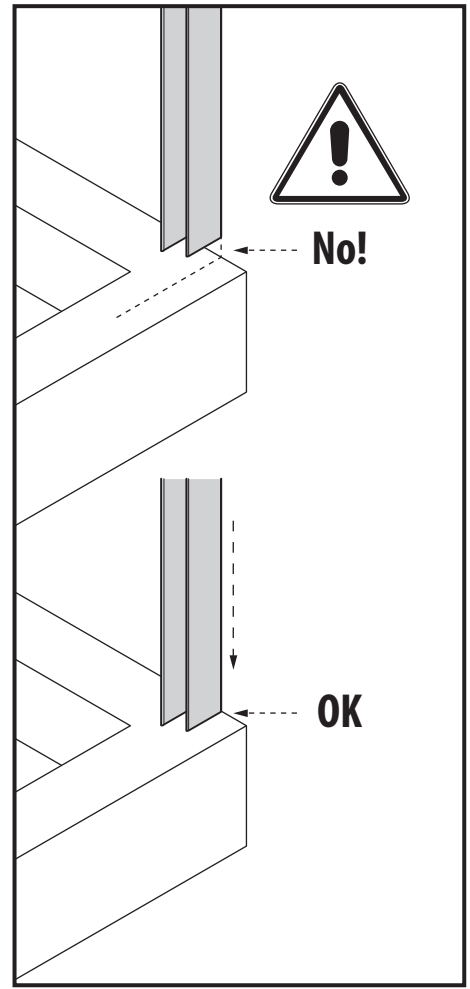
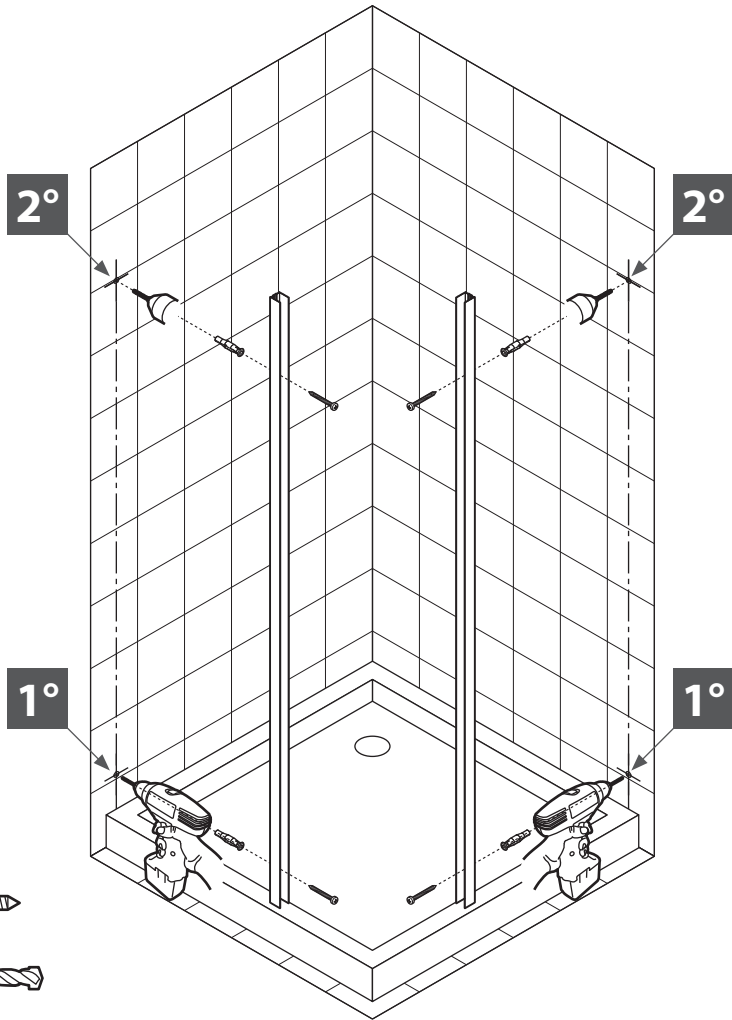

FU8x50 x4



4,5x60 x4



ø8 mm

4

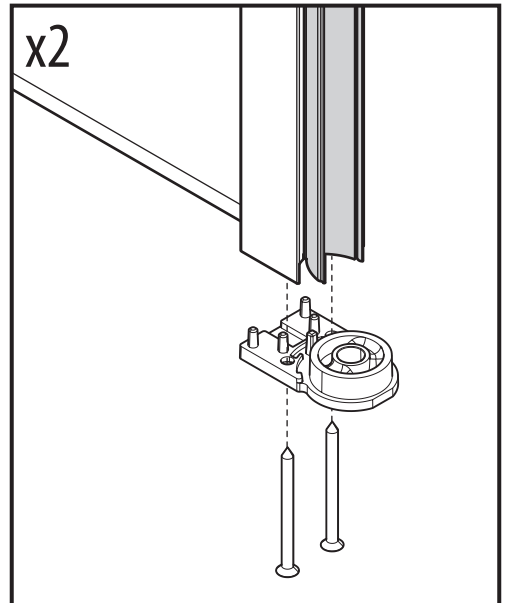
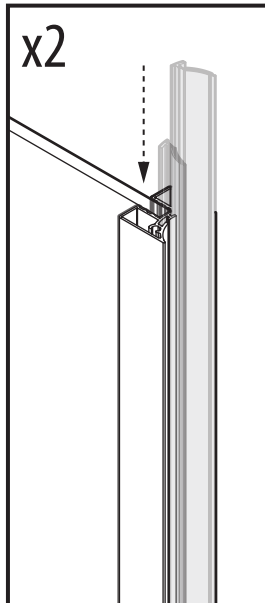
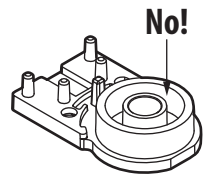
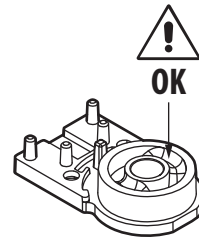
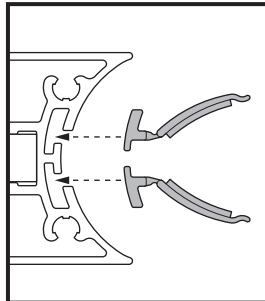
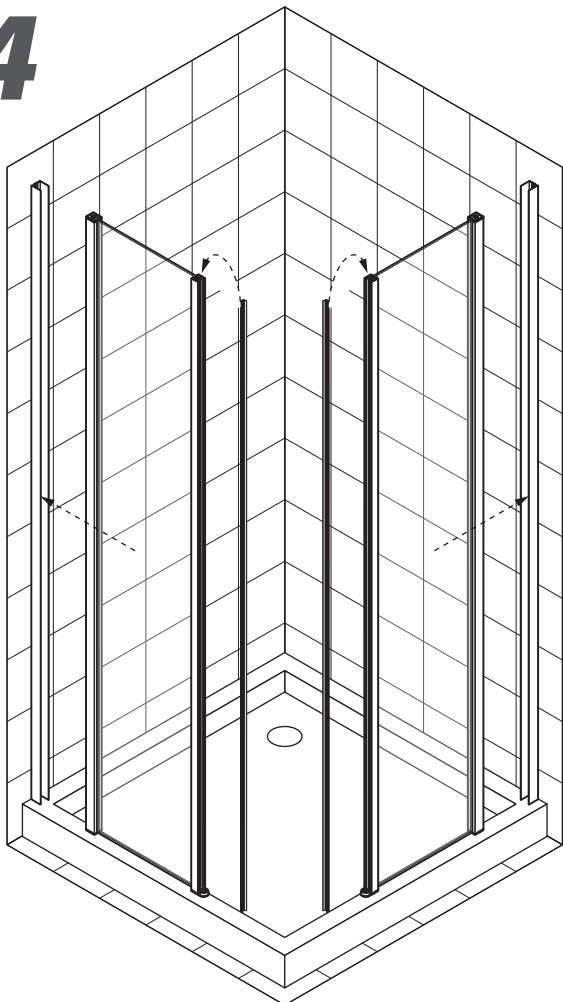

3,5x32 x4

5

5

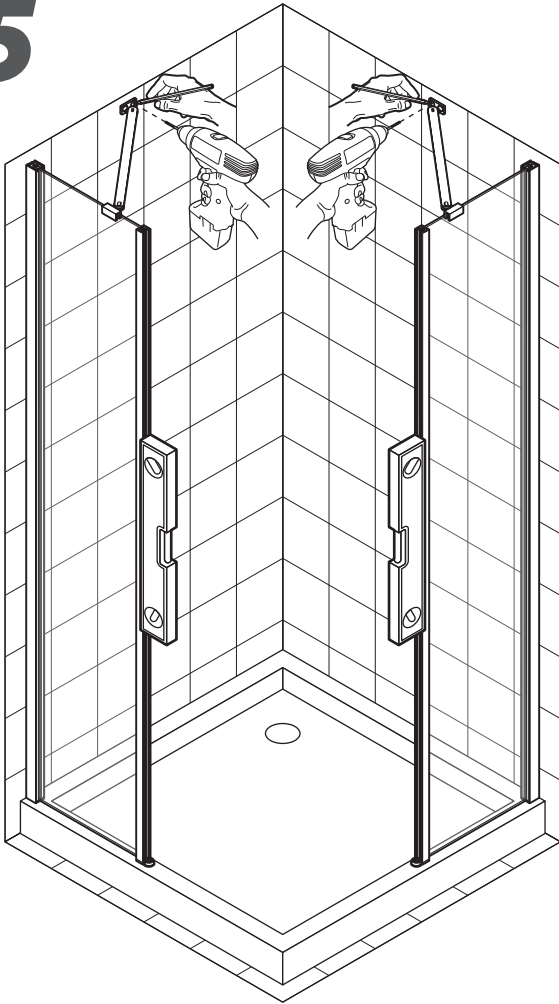

M5 x2



M5x8 x2



M5x10 x2



M5x16 x2



S6 x4



4x35 x4



ø6 mm

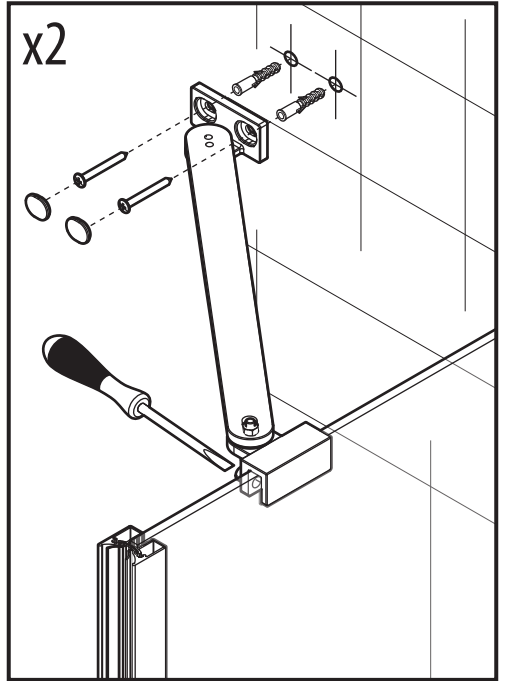
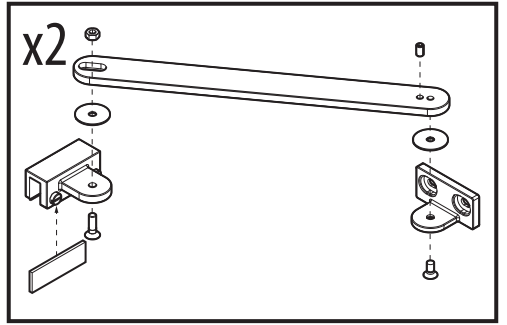

6

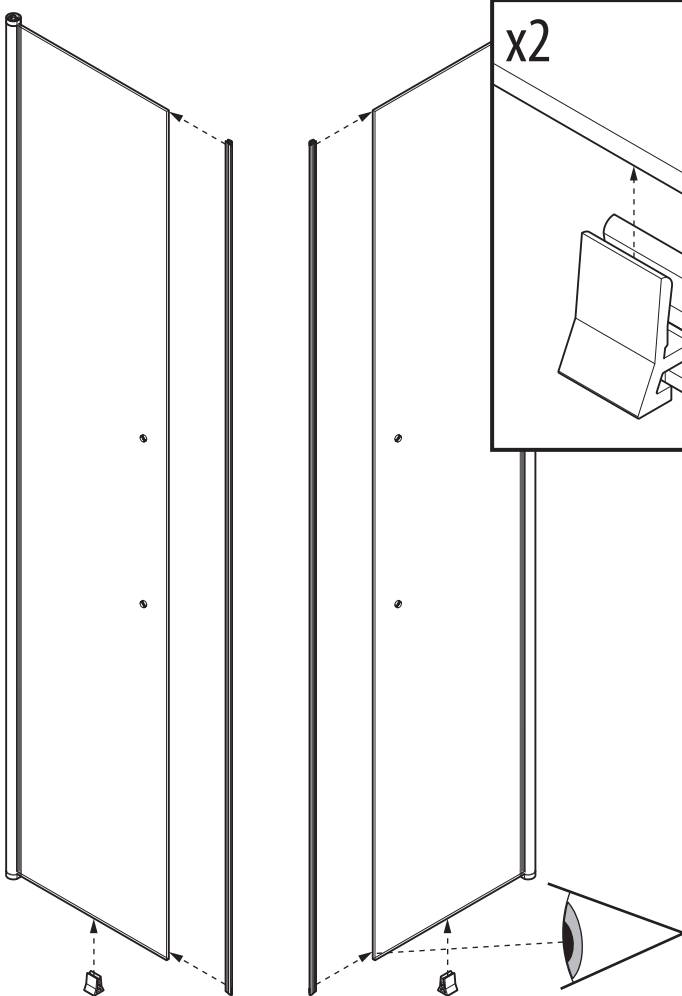

x2

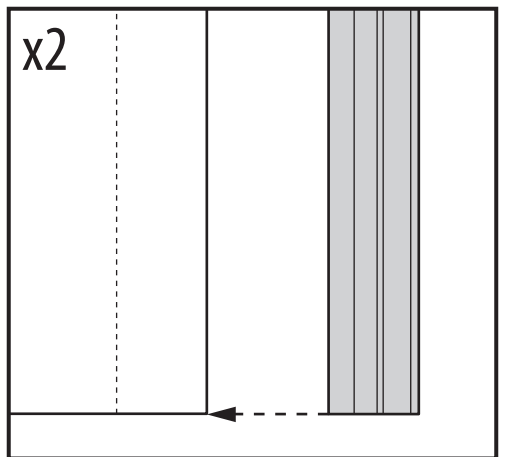
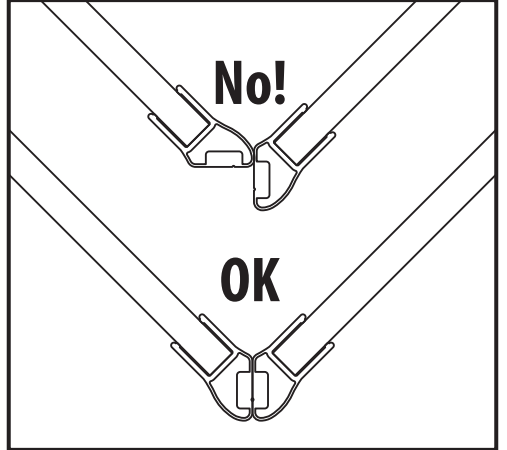
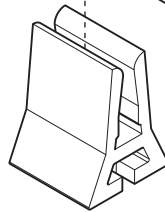

6

7

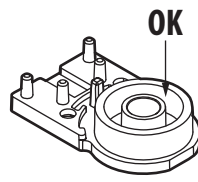
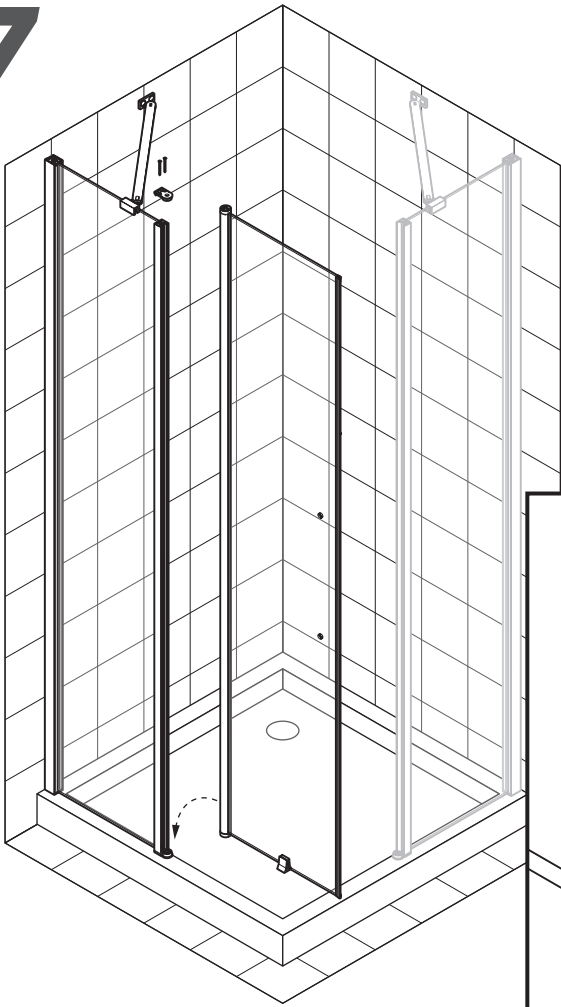

3,5x32 x2

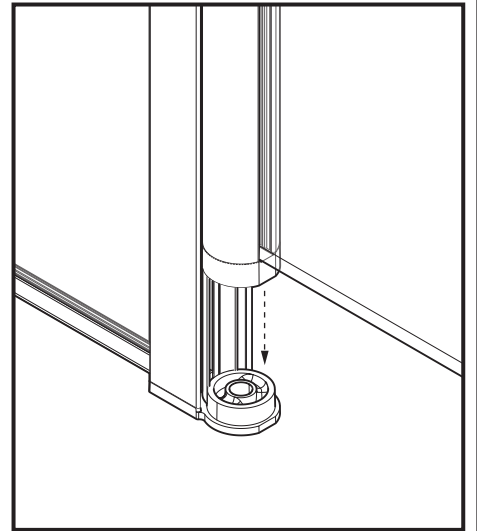
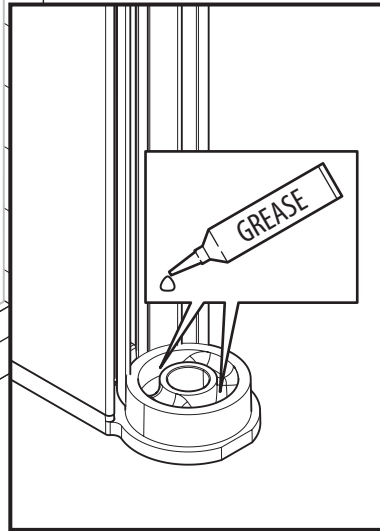
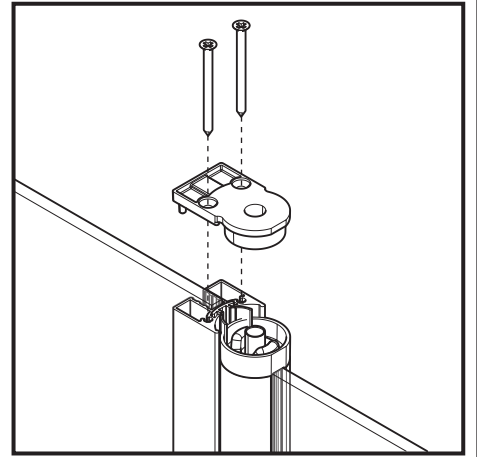

8

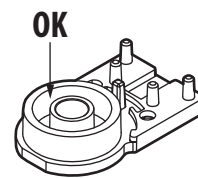
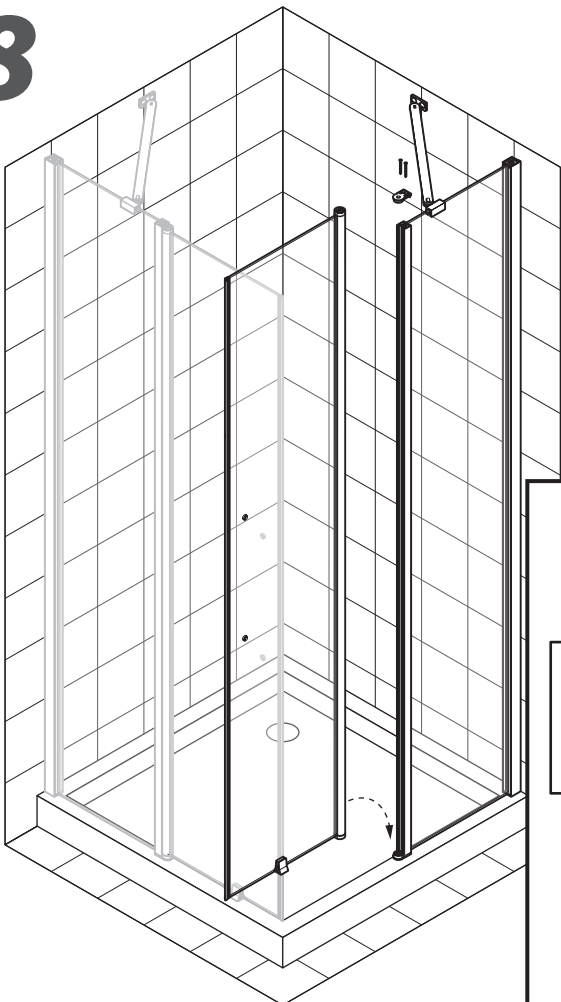

3,5x32 x2

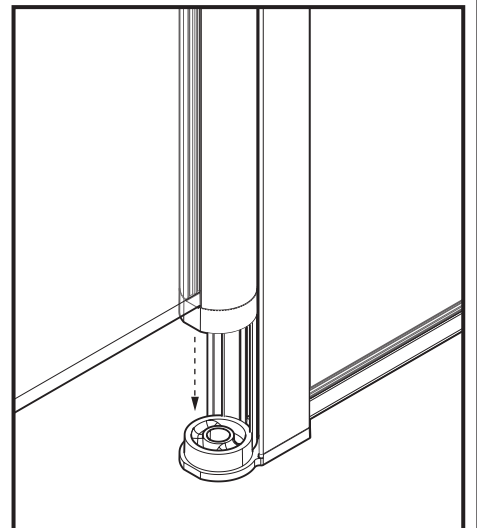
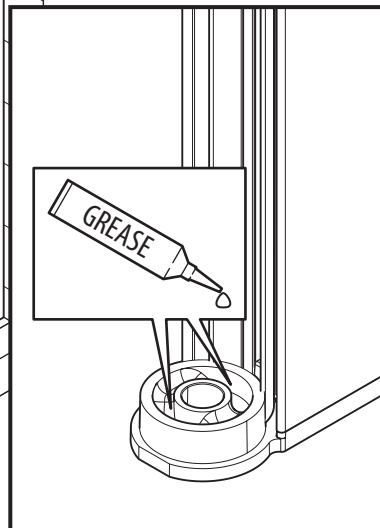
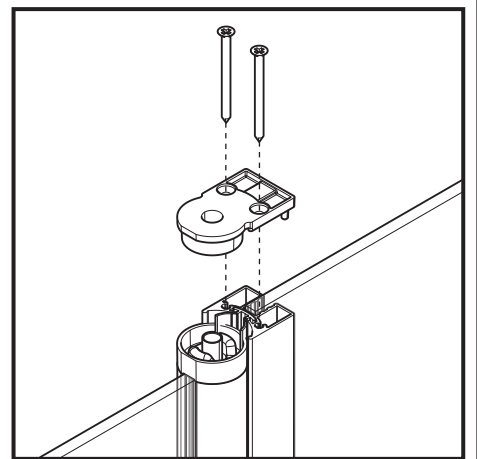

9

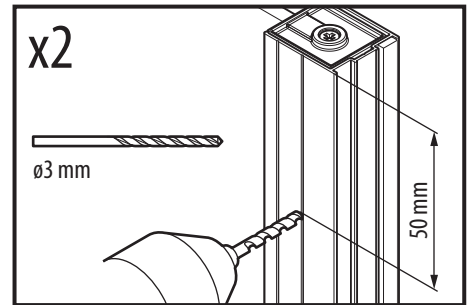
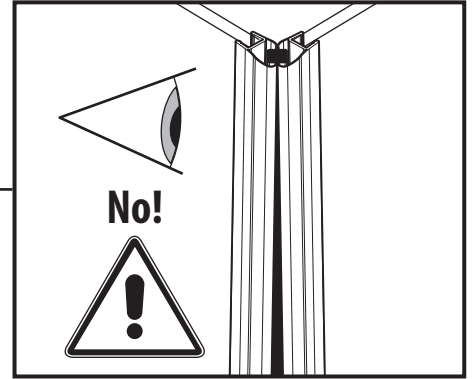
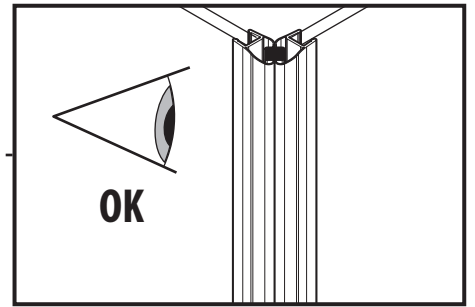
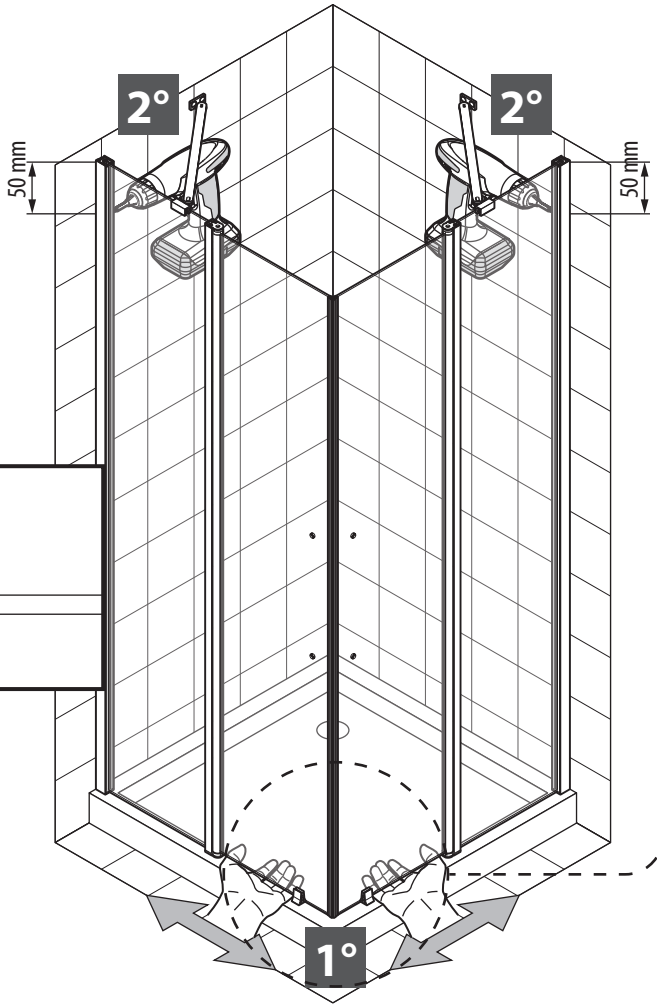
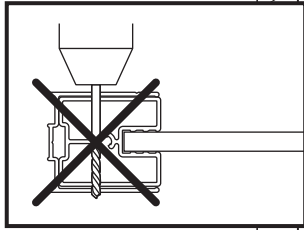

10

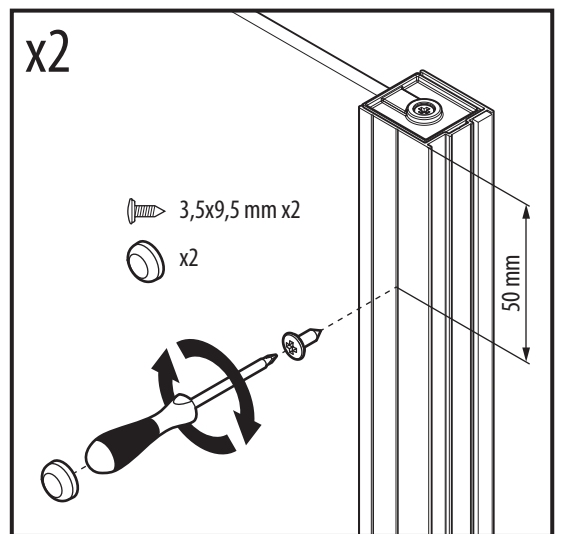
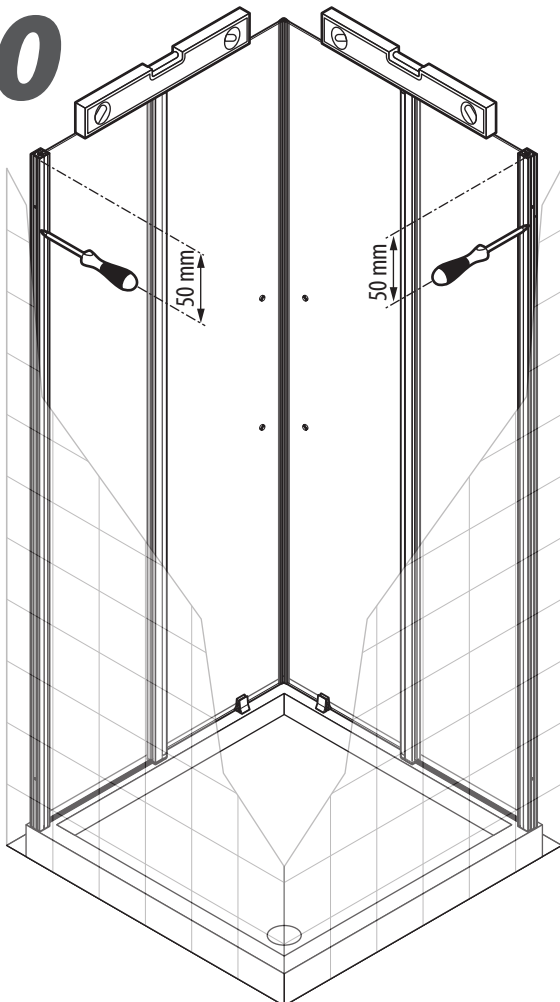

11

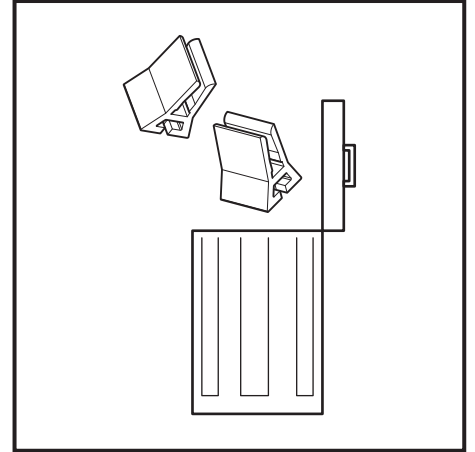
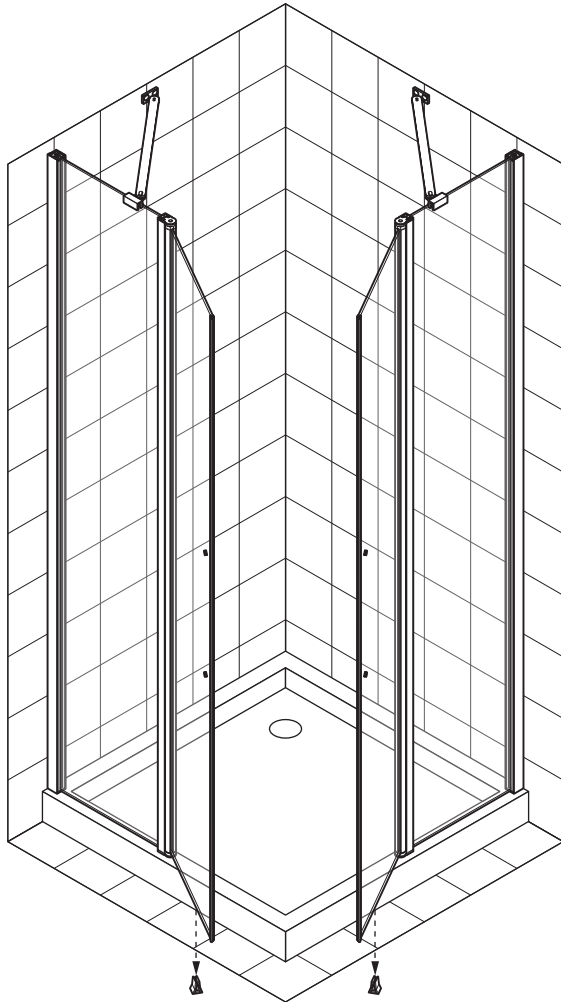

12

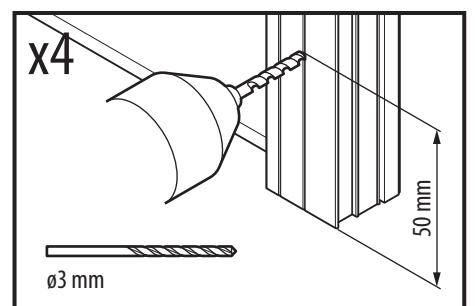
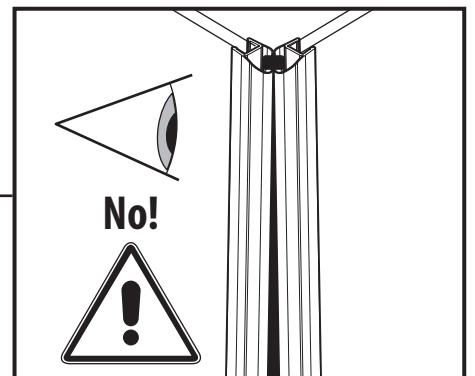
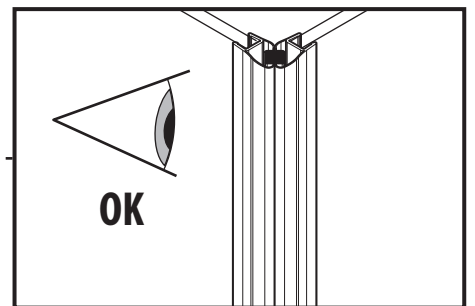
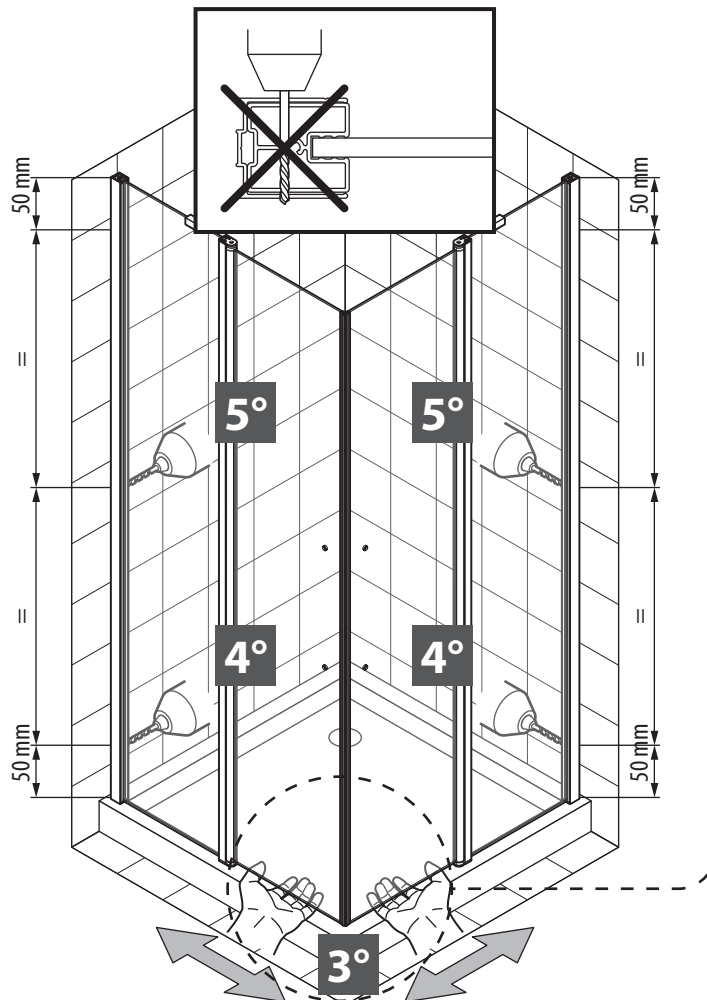

13

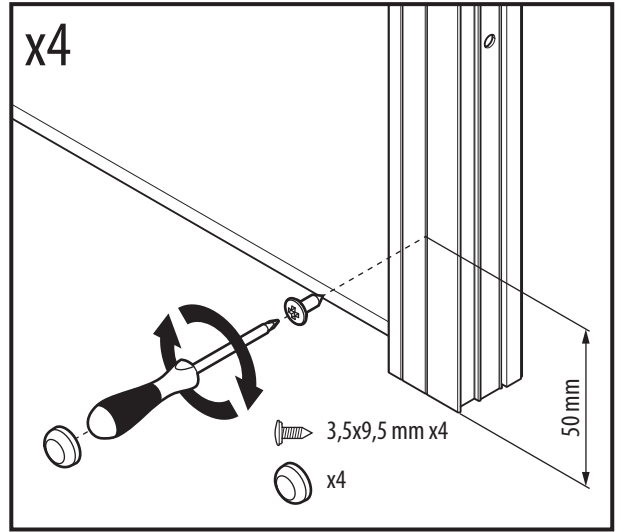
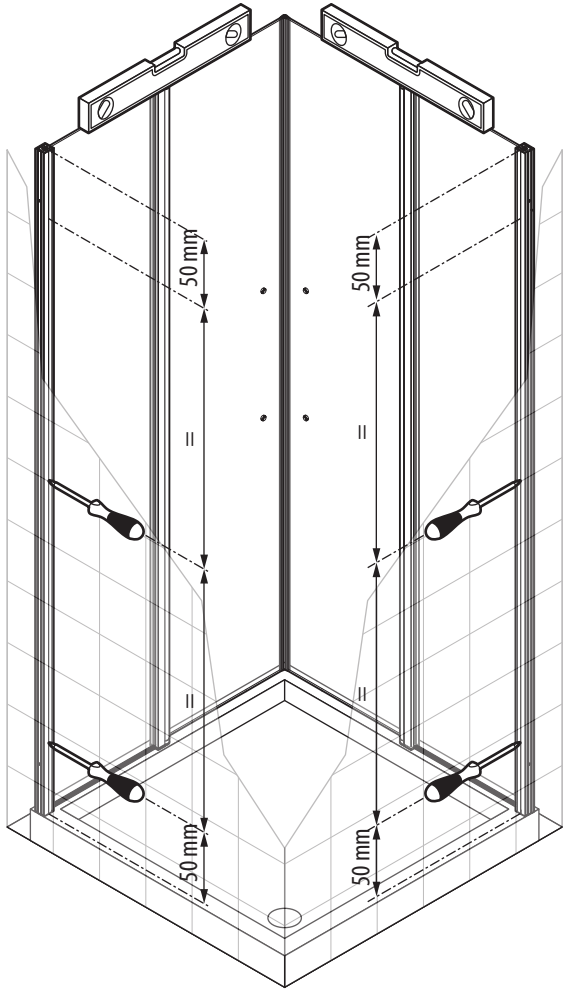

14

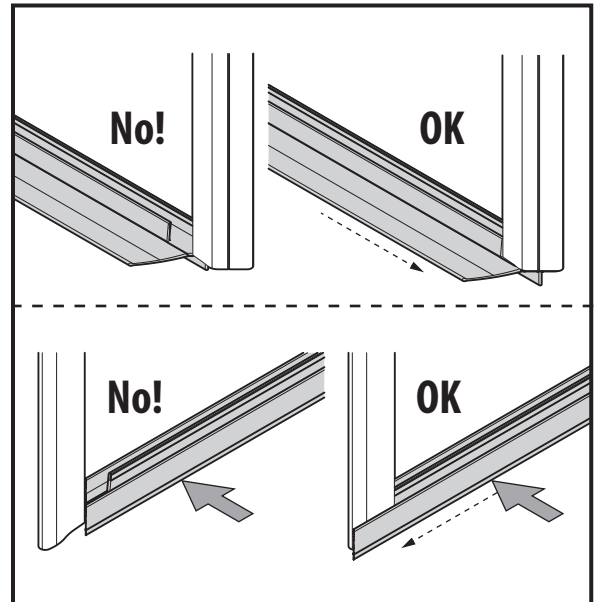
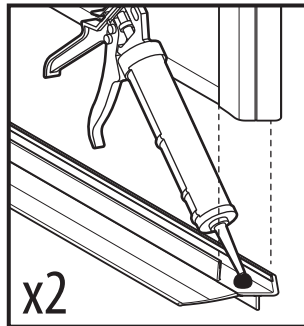
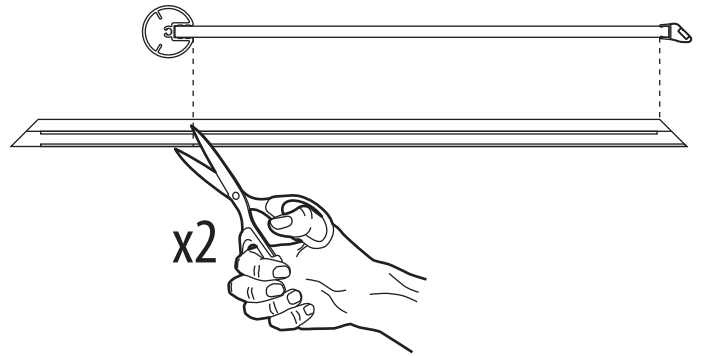
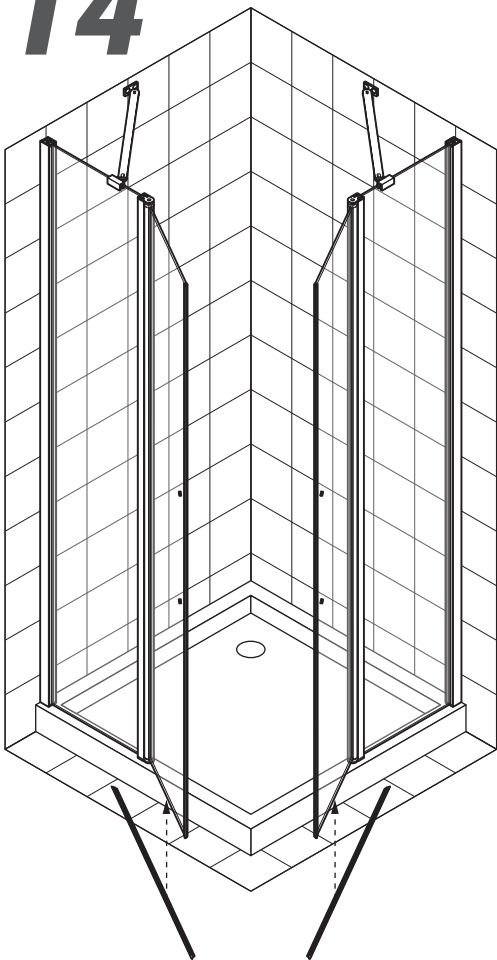

15

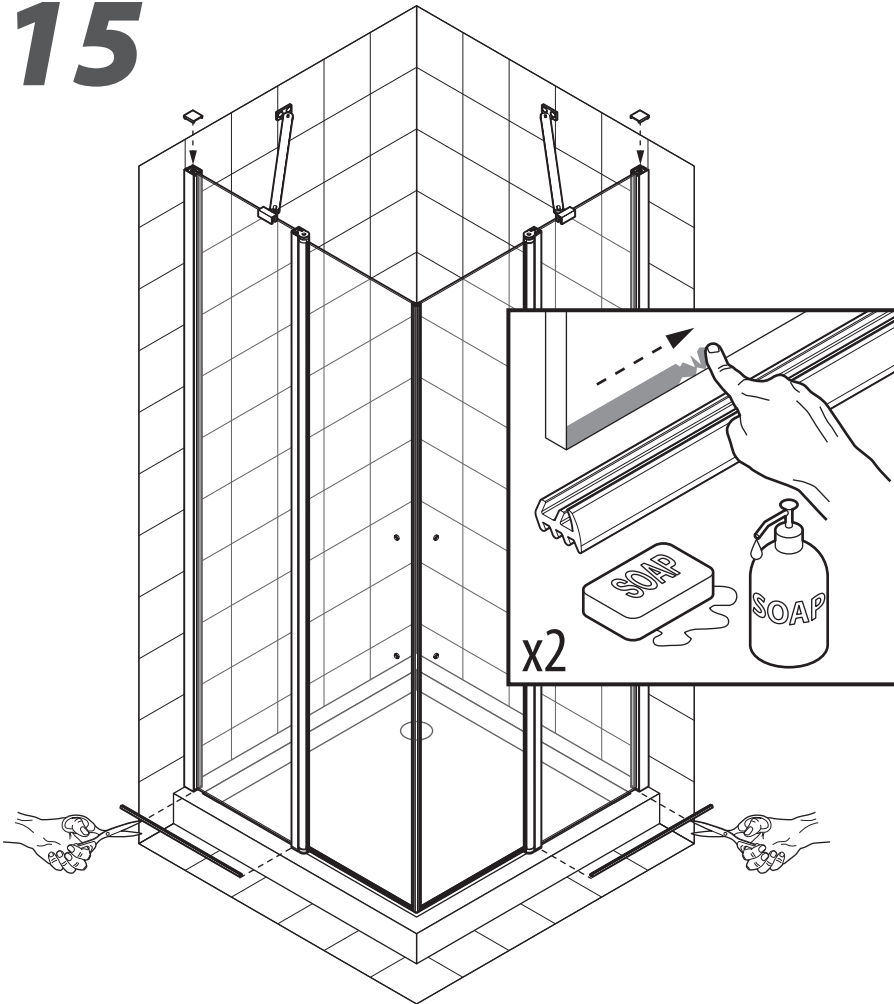

x2

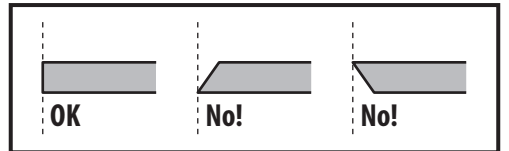
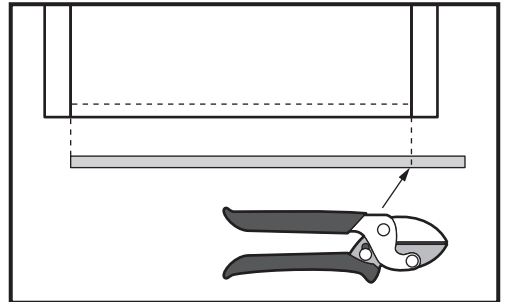
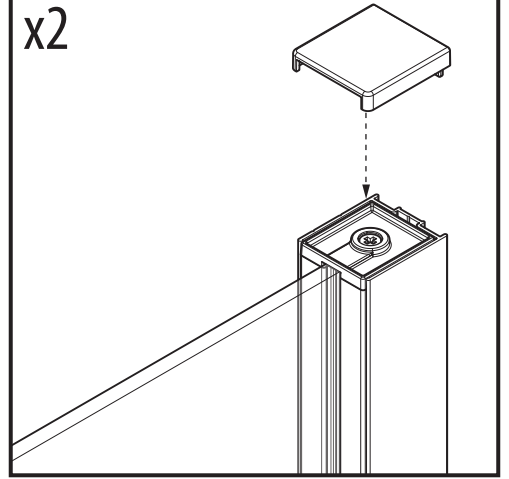

16

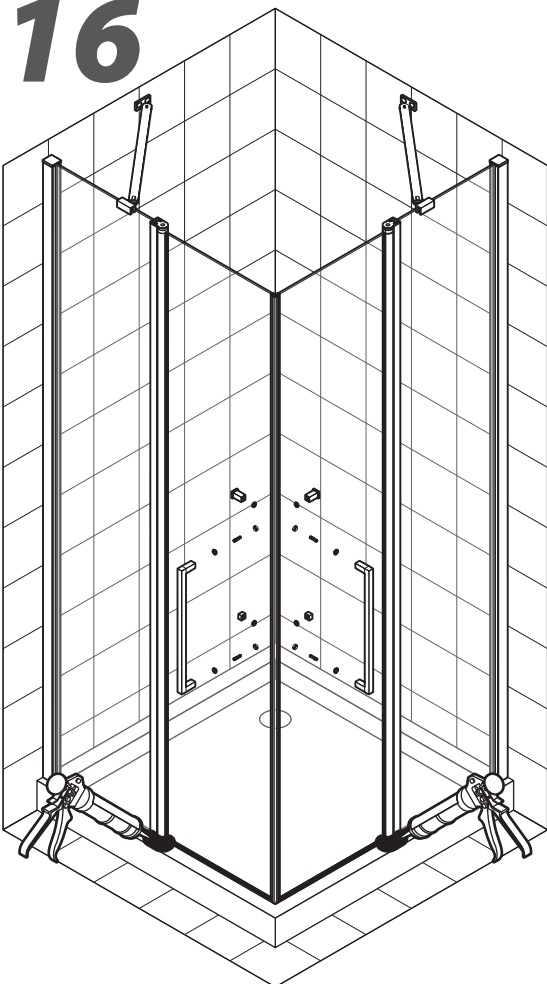

x2

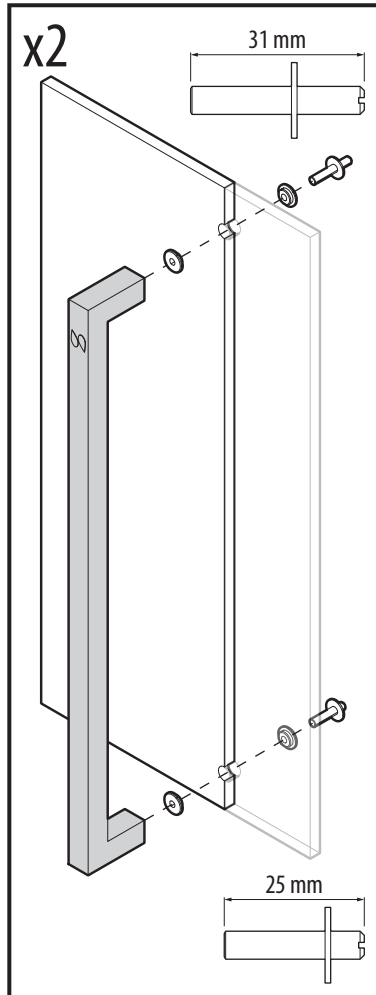

x2

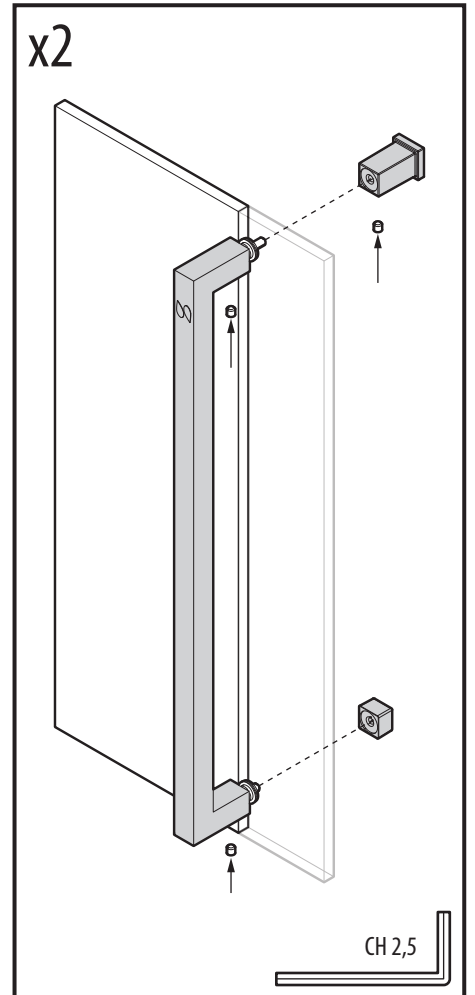

17

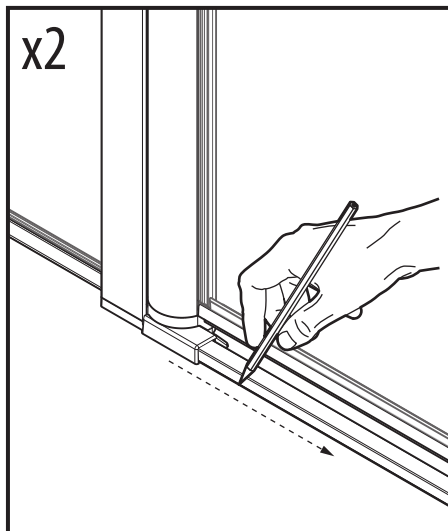
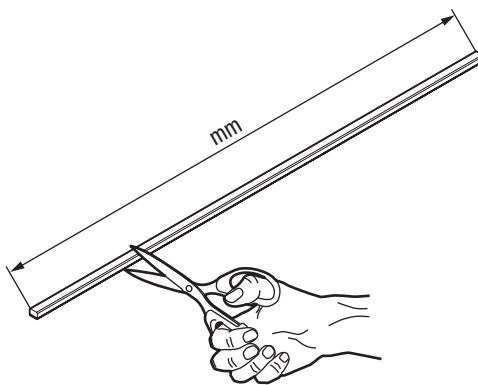
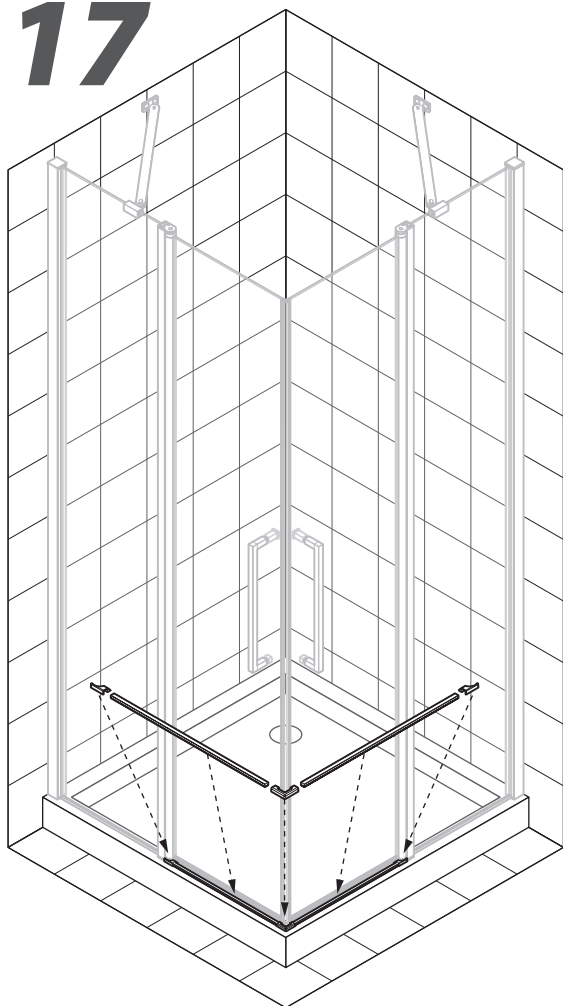

mod. A	mm
57-59	253
59-61	273
61-63	293
65-67	333
67-69	353
69-71	373
73-75	333
75-77	353
76-78	363
77-79	373
79-81	393
81-83	413
85-87	373
87-89	393
89-91	413
91-93	433
95-97	473
97-99	493
99-101	513
101-103	533

18

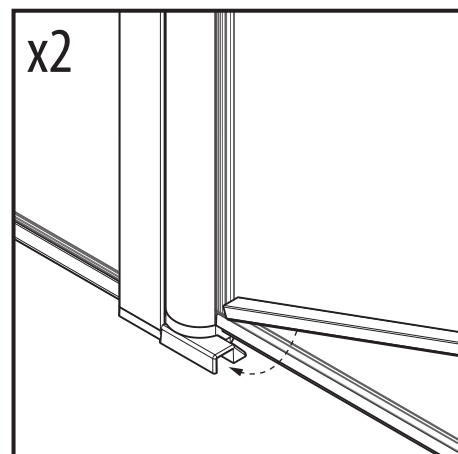
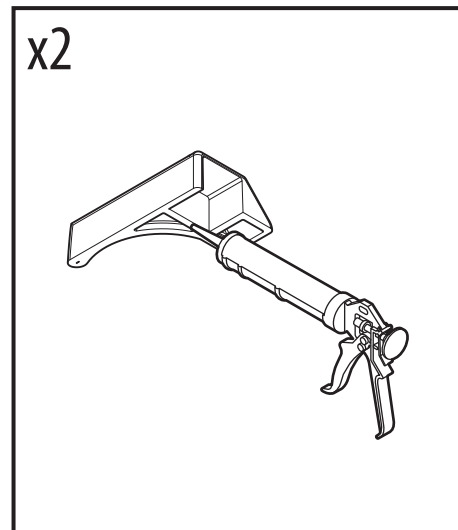
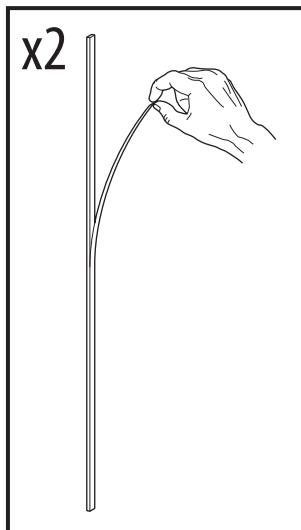
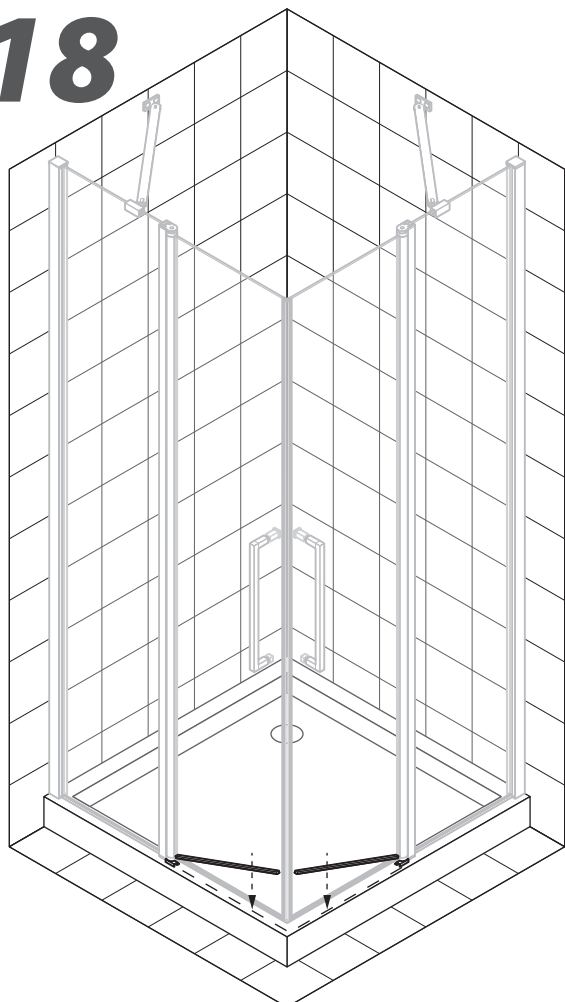

19

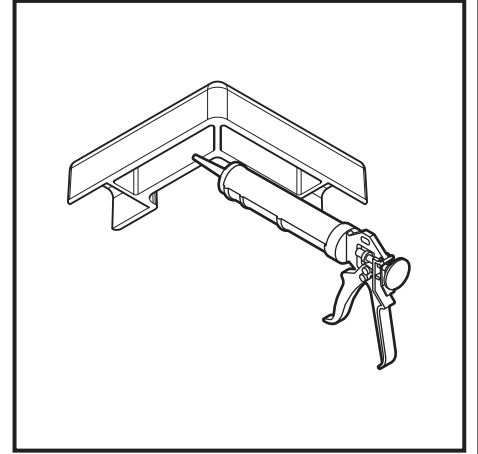
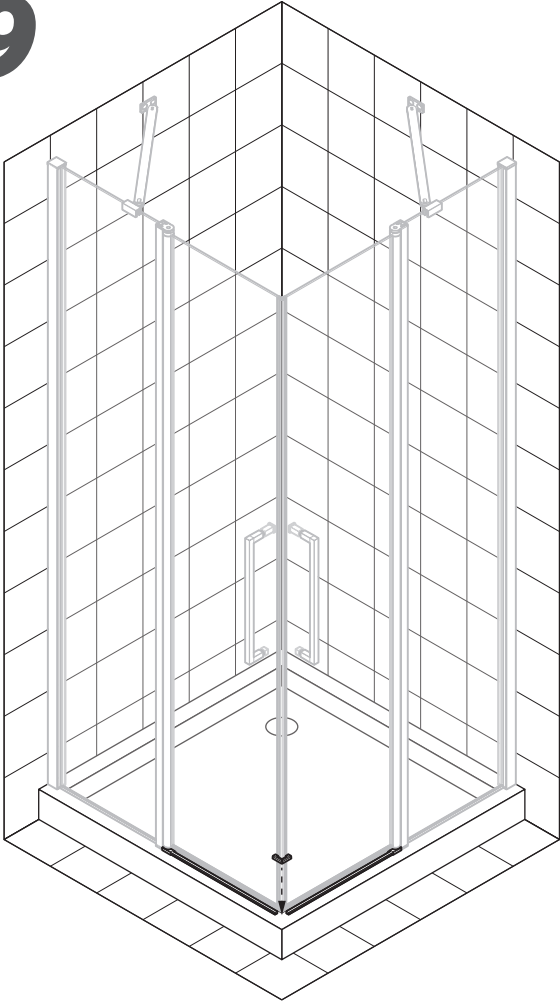

20

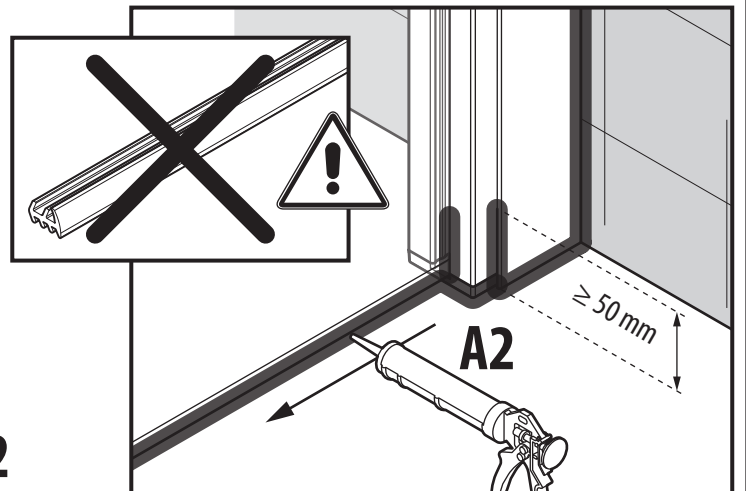
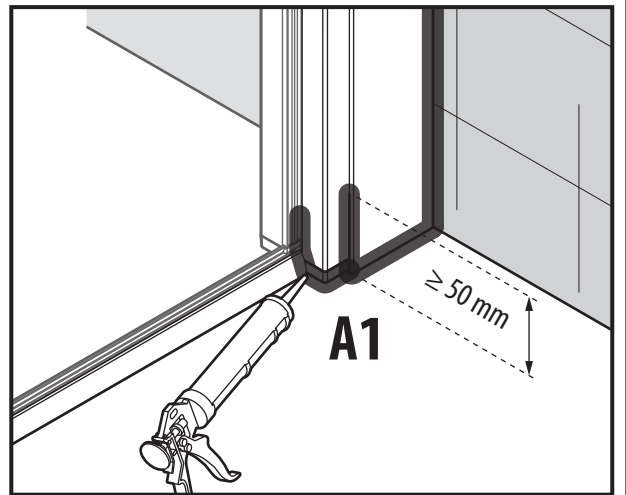
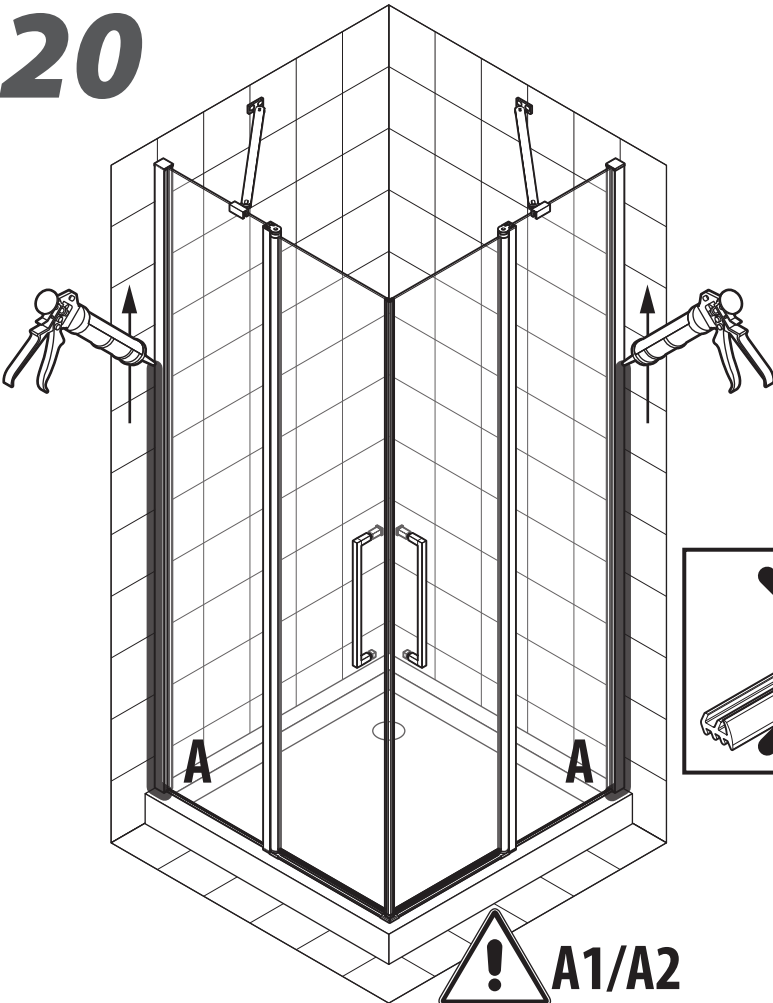

21

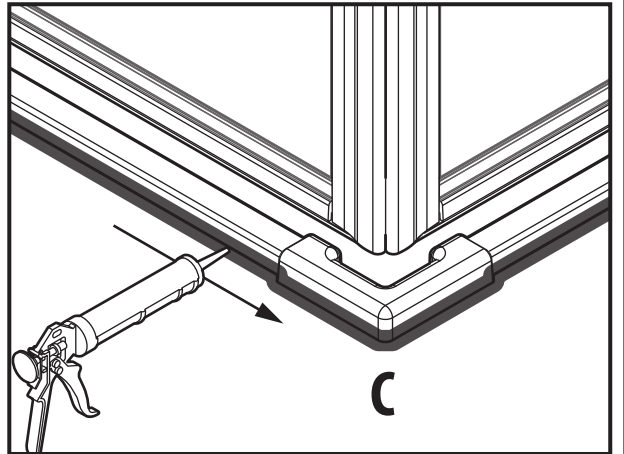
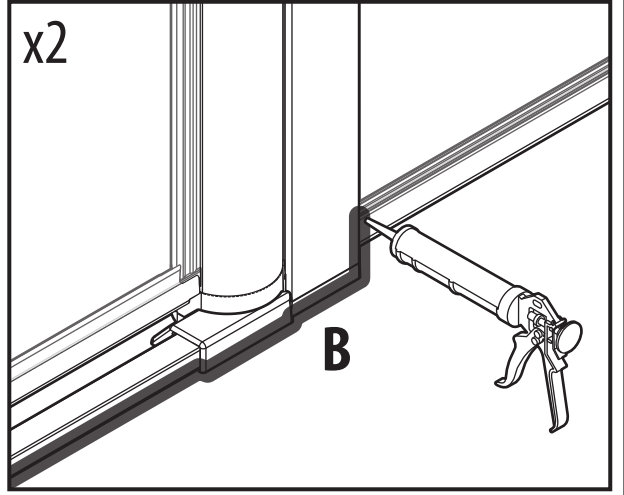
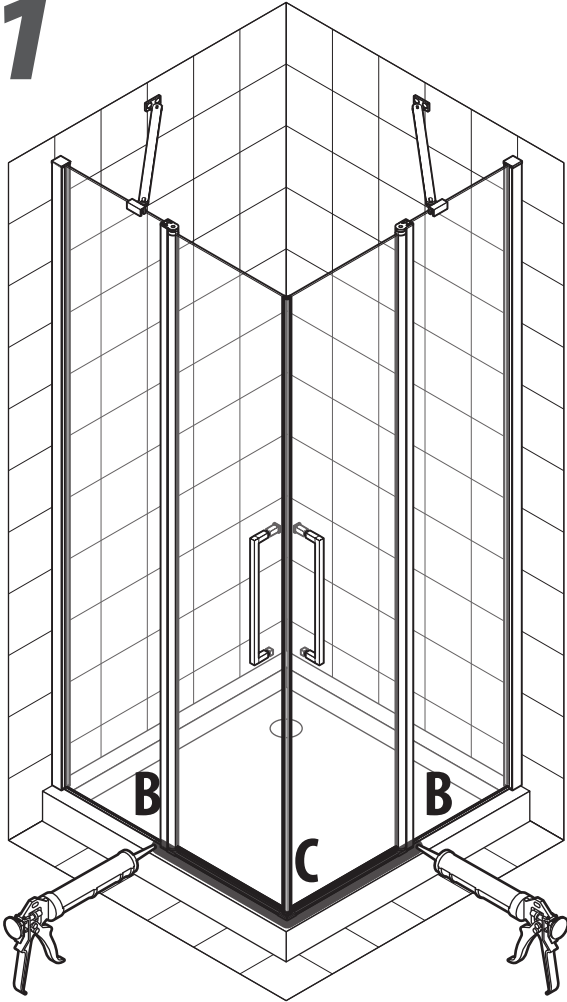

22

